

The BOK-HH is a liquid line Filter Drier for burnout clean-up and wax removal. The BOK-HH incorporates an activated carbon blended solid core for the effective clean-up of systems following a severe burnout.

### Features

- Designed for maximum effectiveness in the clean-up of systems following a severe burnout
- Corrosion resistant epoxy powder paint finish
- Activated carbon blend for soluble contaminant and wax removal
- Solid copper connections
- R-410A compatible



### Specifications

- Filtration: 40 microns
- Maximum working pressure: 680 psig
- UL/CUL file number: SA 3124

### Nomenclature example: BOK 305S-HH

BOK	30	5	S	HH
Series	Unit Size (in cu. in.)	Connection Size (in 1/8")	S = ODF connections (omit for SAE)	Activated carbon Blend

### Dimensional Data

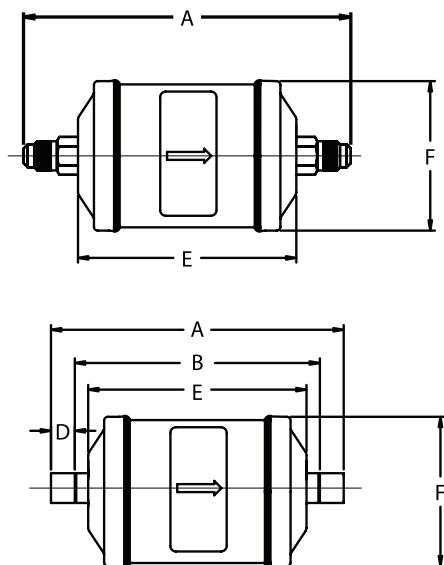

### Ordering Information

PCN	Description	Connection Size	Dimensions (in)					Weight (lbs)
			A	B	D	E	F <sup>1</sup>	
060223	BOK-082-HH	1/4 SAE	5.63	--	--	3.94	2.94	1.00
064591	BOK-082SH	1/4 ODF	5.00	4.31	0.38	3.81	2.63	
060224	BOK-083-HH	3/8 SAE	5.94	--	--	3.94	2.94	
057995	BOK-083SH	3/8 ODF	5.38	4.06	0.63	3.81	2.63	
060240	BOK-162-HH	1/4 SAE	6.44	--	--	3.94	2.94	
064592	BOK-162S-HH	1/4 ODF	6.03	5.29	0.38	4.63	3.13	
060241	BOK-163-HH	3/8 SAE	6.75	--	--	3.94	2.94	
060242	BOK-163S-HH	3/8 ODF	6.13	5.25	0.94	4.63	2.88	
060228	BOK-164-HH	1/2 SAE	6.94	--	--			
060229	BOK-164S-HH	1/2 ODF	6.19	5.16	0.50			
060230	BOK-165-HH	5/8 SAE	7.44	--	--	7.50	3.06	3.75
060231	BOK-165S-HH	5/8 ODF	6.38	5.13	0.63			
060232	BOK-303-HH	3/8 SAE	9.63	--	--			
060233	BOK-304-HH	1/2 SAE	9.88	--	--			
060234	BOK-304S-HH	1/2 ODF	9.13	8.13	0.50	763	3.69	4.75
060235	BOK-305-HH	5/8 SAE	10.31	--	--			
060236	BOK-305S-HH	5/8 ODF	9.31	8.06	0.63			
060237	BOK-414-HH	1/2 SAE	10.00	--	--	763	3.69	4.75
060238	BOK-415-HH	5/8 SAE	9.25	8.25	0.50			
060239	BOK-417S-HH	7/8 ODF	10.44	--	--			
064593	BOK-415S-HH	5/8 ODF	9.25	8.25	0.50			

<sup>1</sup> Does not include weld bead

## BOK-HH Liquid Line Burnout Filter Drier

Description	Connections	Flow Capacity <sup>1,4</sup> Tons @ 1 psi ΔP (For kW, multiply tons by 3.5)						Water Capacity <sup>2</sup> Drops Of Water <sup>3</sup>															
		R-12		R-134a		R-22		R-407C		R-410A		R-404A/R-507		R-502									
		75°F	125°F	75°F	125°F	75°F	125°F	75°F	125°F	75°F	125°F	75°F	125°F	75°F	125°F								
BOK 08 2-HH	1/4 SAE	1.2	1.5	1.6	1.6	1.6	1.6	1.1	180	118													
BOK 082SH	1/4 ODF	-	3.1	3.4	3.4	3.3	2.2	-	-														
BOK 08 3-HH	3/8 SAE	3.2	3.9	4.2	4.2	4.1	2.8	180	118	88	71	78	59	74	45	66	38	93	71	109	79		
BOK 083SH	3/8 ODF	-	4.2	4.6	4.6	4.5	3.0	-	-														
BOK 16 2-HH	1/4 SAE	1.2	1.5	1.6	1.6	1.6	1.1																
BOK 16 3-HH	3/8 SAE	3.6	4.3	4.7	4.7	4.6	3.1																
BOK 16 3S-HH	3/8 ODF	4.8	5.8	6.3	6.3	6.2	4.2																
BOK 16 4-HH	1/2 SAE	7.0	8.6	9.3	9.3	9.1	6.2	209	143	171	141	153	117	91	56	77	41	182	141	135	100		
BOK 16 4S-HH	1/2 ODF	8.4	10.2	11.1	11.1	10.9	7.4																
BOK 16 5-HH	5/8 SAE	10.5	12.8	13.9	13.9	13.6	9.3																
BOK 16 5S-HH	5/8 ODF	10.5	12.8	13.9	13.9	13.6	9.3																
BOK 30 3-HH	3/8 SAE	3.6	4.3	4.7	4.7	4.6	3.1																
BOK 30 4-HH	1/2 SAE	8.1	9.9	10.7	10.7	10.5	7.2																
BOK 30 4S-HH	1/2 ODF	8.9	10.8	11.7	11.7	11.5	7.8	552	367	300	245	267	204	234	146	160	94	318	247	342	249		
BOK 30 5-HH	5/8 SAE	11.1	13.5	14.6	14.6	14.3	9.8																
BOK 30 5S-HH	5/8 ODF	12.0	14.6	15.8	15.8	15.5	10.6																
BOK 41 4-HH	1/2 SAE	8.4	10.2	11.1	11.1	10.9	7.4																
BOK 41 5-HH	5/8 SAE	13.4	16.3	17.7	17.7	17.4	11.8	623	410	427	344	379	282	256	155	220	125	454	342	380	274		
BOK 41 5S-HH	5/8 ODF	13.4	16.3	17.7	17.7	21.1	14.4																
BOK 41 7S-HH	7/8 ODF	16.3	19.8	21.5	21.5	21.1	14.4																

<sup>1</sup> All ratings in accordance with ARI Standard 710-04. 86°F liquid refrigerant temperature  
5°F saturated vapor temperature  
3.1 lbs./min./ton for R-134a  
2.9 lbs./min./ton for R-22 and R-407C  
4.0 lbs./min./ton for R-404A/507 and R-12  
2.7 lbs./min./ton for R-410A

<sup>2</sup> Water Capacities are based on:  
Equilibrium Point Dryness (EPD) of:  
50 parts per million for R-134a, R404-A/507,  
R-410A and R-407C  
60 parts per million for R-22  
15 parts per million for R-12

<sup>3</sup> 20 drops of water = 1 gram = 1 cc

<sup>4</sup> For 2 PSI ΔP, Multiply values by 1.4

## Liquid Refrigerant Holding Capacity - Ounces

Unit Size	R-12		R-134a		R-22		R-407C		R-410A		R-404A/507		R-502	
	75°F	125°F	75°F	125°F	75°F	125°F	75°F	125°F	75°F	125°F	75°F	125°F	75°F	125°F
08	7.3	6.6	6.7	6.0	6.6	5.9	6.3	5.5	5.9	4.9	5.8	4.9	6.7	5.9
16	13.9	12.7	12.8	11.5	12.6	11.3	12.0	10.5	11.2	9.4	11.1	9.3	12.9	11.3
30	21.8	19.9	20.1	18.1	19.8	17.8	18.9	16.6	11.7	14.9	17.4	14.7	20.2	17.7
41	29.3	26.8	26.9	24.4	26.6	23.9	25.4	22.3	23.7	20.0	23.3	19.7	27.2	23.8