

Instruction Sheet

PA-00319

September 2008

EC3-X32 Superheat Controller

EC3-X32 Superheat Controller with TCP/IP Communication Capability

Description

EC3-X32 is the superheat controller with TCP/IP connection used in conjunction with Emerson Electrical Control Valves EX4...EX8.

Note: This document contains short form instructions for experienced users.



Safety Instructions

- Read installation instructions thoroughly. Failure to comply can result in device failure, system damage or personal injury.
- The product is intended for use by persons having the appropriate knowledge and skills.
- Disconnect all voltages from system before installation.
- Do not operate system before all cable connections are completed.
- Comply with local electrical regulations when wiring.

Note: The EC3-X32 series contains a lead, acid gel rechargeable battery. The battery must NOT be disposed of with other commercial waste. Instead, it is the user's responsibility to pass it to a designated collection point for the safe recycling of batteries (harmonized directive 98/101/EEC). For further information contact your local environmental recycling center.

Technical data

Power supply	24VAC ±10%; 50/60Hz; 1A
Power consumption	25VA max. including EX4 ... EX8
Plug-in connector	Removable screw terminals wire size 12-20 AWG
Grounding	1/4 in spade earth connector
Protection class	IP20
COM, TCP/IP connection	RJ45 Ethernet
Connection to optional local ECD-002	ECC-Nxx or CAT5 cable with RJ45 connectors
Digital Inputs	0/24VAC/DC for stop/start function
NTC input	Emerson temperature sensor ECN-N60
4-20 mA Analog input	Emerson PT4-07M / PT4-18M / PT4-30M
4-20 mA Analog output	For connection to any 3 rd party controller with 12/24VDC power supply and appropriate burden
Output alarm relay	SPDT contact 24V AC/DC, 2 Amp inductive load (If L2 = 1)
Activated:	During normal operation (no alarm condition)
Deactivated:	During alarm condition or power supply is OFF
Output pump down relay	SPDT contact 24V AC/DC, 2 Amp inductive load (If L2 = 1)
Activated:	During normal operation
Deactivated:	All other conditions
Stepper motor output for EX4...EX8	Maximum current 0.8A with nominal 24VDC operating voltage

Mounting

The EC3-X32 is designed to be mounted onto a standard DIN rail.

Electrical installation

- Refer to the electrical wiring diagram for electrical connections.
- Do not apply voltage to the controller before completion of wiring.
- Ground the metal housing with a 1/4 in spade connector.
- **Important:** Keep controller and sensor wiring well separated from mains wiring. Minimum recommended distance 1.2 in.

Warning: Use a class II category transformer for 24VAC power supply. Do not ground the 24VAC lines. We recommend to use individual transformers for EC3 controller and for 3rd party controllers to avoid possible interference or grounding problems in the power supply. Connecting any EC3 inputs to mains voltage will permanently damage the EC3.

Digital input status is dependant to operation of compressor/thermostat

Commander	Operating condition	Digital input
Compressor	Compressor starts	Closed / 24V (Start)
	Compressor stops	Open / 0V (Stop)
Thermostat	Demand (compressor must be ON)	Closed / 24V (Start)
	No demand	Open / 0V (Stop)

Preparation for Start-up

- Evacuate the entire refrigeration circuit.
- **Warning:** Emerson Electrical Control Valves EX4...EX8 are delivered at half open position. Do not charge system before closure of valve.
- Apply supply voltage 24V to EC3 while the digital input is 0V (open). The valve will be driven to close position.
- After closure of valve, start to charge the system with refrigerant.

Possibilities of connecting EC3-X32 to a network or PC

A TCP/IP Controller Readme file is available on the www.eCopeLand.com website to provide detailed information about TCP/IP Ethernet connectivity. Please refer to this file if you need information beyond the contents of this instruction sheet.

- 1) Connect the EC3-X32 using the optional ECC-Nxx cable assembly or a standard CAT5 network cable with RJ45 plugs assembly to a network or router that enables the controller to receive a dynamic TCP/IP address or
- 2) Connect the EC3-X32 to a computer using a crossover cable plugged directly into the Ethernet port. In this case, the TCP/IP address of the computer must be manually modified to be compatible with the default address of the controller. Refer to the TCP/IP Controller-Readme file for more details.

Wiring

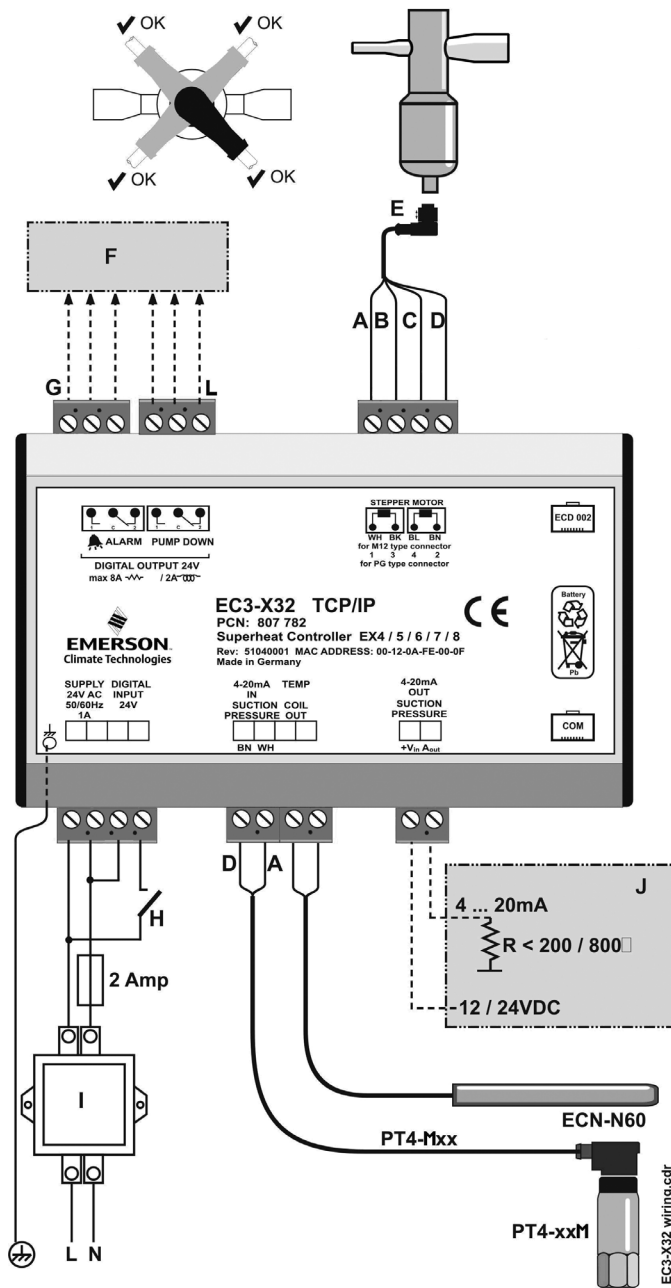

- A: White wire B: Black wire C: Blue wire D: Brown wire
- E: M12 Plug cable assembly EX5-Nxx for connection to EX4/EX5/EX6/EX7/EX8
- F: Remote control panel, system controller
- G: Alarm relay, dry contact. Relay coil is not energized at Alarm or power off
- H: Digital input (0V/open = Stop; 24V/closed = Start)
- I: Transformer Class II, 24VAC secondary / 25VA
- J: Third party controller (can use the analog output signal from EC3)

Setting and Visualizing Data: WebPages (recommended method)

Important: Make sure that digital input is 0V (open). Turn the power supply ON.
Four parameters i.e. refrigerant type (u0), pressure sensor type (uP), valve type (ut) and control mode can be set only when digital input is open (0V) while the power supply is ON (24V). This feature is for added safety to prevent accidental damage of compressors and other system components. All other parameters can be modified at any time.

The EC3-X32 has a TCP/IP Ethernet communication interface enabling the controller to be directly connected to a network or a PC via the standard Ethernet port. The EC3-X32 controller has embedded WebPages to enable the user to visualize the parameter lists using real text labels.

To view WebPages on the PC, a standard WebBrowser like Internet Explorer® or Mozilla Firefox and JRE Java Runtime Environment is needed. JRE can be downloaded at no charge from the www.java.com website.

Open the Internet browser program on the computer and, if EC3-X32 is connected directly to PC with a crossover cable enter the default TCP/IP address of the controller (**192.168.1.101**) into the address line, or the dynamic address from the DHCP server from network/Router. Refer to the **TCP/IP Controller-Readme** file if a specific port is required.

It is possible to identify the dynamic TCP/IP address assigned by DHCP of the Router or network, refer to the TCP/IP Controller-Readme file.

After a few moments, the default monitoring page should be displayed. If the browser does not open the default page or display active data, the user should check the Internet browser "Option" configuration. Refer to the TCP/IP Controller-Readme file.

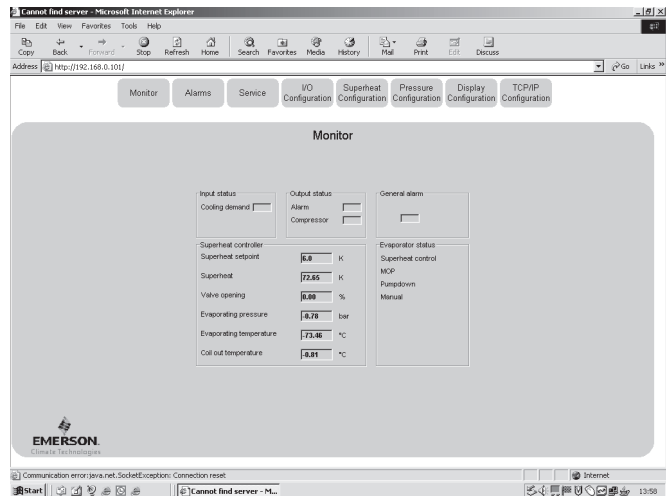

The Monitoring and Alarm WebPages are read only and therefore it is not necessary to enter a username or password. A username and password will be requested upon the initial request to any of the other WebPages. The factory default settings are:

Username: "EmersonID" , Password: "12"

The default settings may be modified on the Display configuration page.

Press the tabs at the top of the Monitoring page with a left click of the mouse button to enter the respective Webpage.

The parameters will be visualized in real text together with the program code as defined in the parameter list below.

After the parameters have been modified, the complete list of settings can be saved to the memory of the computer and used later to upload into another controller. This can save a considerable amount of time when using multiple controllers and over a period of time, a library can be created containing the parameter lists for equipment for different applications.

It is also possible to display live graphical data from the controller. Superheat, evaporating pressure, coil-out temperature and evaporating temperature are available on a 15 minutes rolling chart. Refer to the TCP/IP Controller-Readme file for a complete description of the features available for the TCP/IP series of controllers.

Alternative procedure for parameter modification using ECD-002

Note: Some of the functions/parameters (manual control and TCP/IP configuration) can not be modified when using ECD-002 comparing to a set-up by PC via TCP/IP. **Warning:** All alarms are disabled during manual control. We do not recommend unattended operation of system during manual control.

The parameters can be accessed via the 4-button keypad. The configuration parameters are protected by a numerical password. The default password is "12". To select the parameter configuration:

- Press the **PRG** button for more than 5 seconds, a flashing "0" is displayed.
- Press **▲** or **▼** until "12" is displayed (password).
- Press **SEL** to confirm password.
- Press **▲** or **▼** to show the code of the parameter that has to be changed.
- Press **SEL** to display the selected parameter value.
- Press **▲** or **▼** to increase or decrease the value.
- Press **SEL** to temporarily confirm the new value and display its code.

Repeat the procedure from the beginning "press **▲** or **▼** to show..."

To exit and save the new settings:

- Press PRG to confirm the new values and exit the parameters modification procedure.

To exit without modifying any parameters:

- Do not press any button for at least 60 seconds (TIME OUT).

Special Functions

- Press **▲** or **▼** together for more than 5 seconds, a flashing "0" is displayed.
- Press **▲** or **▼** until the password is displayed (default = "12"). If password was changed, select the new password.
- Press **SEL** to confirm password. A "0" is displayed and the Special Function mode is activated.
- Press **▲** or **▼** to select the function. The number of special functions is dynamic and controller dependent. See list below.
 - 0: Reset controller to factory settings (this action is possible only when digital input is 0V i.e. open).
 - 1: Displays the current TCP/IP address.
 - 2: Assign temporary 192.168.1.101 as TCP/IP address if EC3-X32 has different address.
- Press **SEL** to activate the function without leaving the special function mode.
- Press **PRG** to activate the function and leave the special function mode.

ECD-002 Display/Keypad Unit (LEDs and Button Functions)

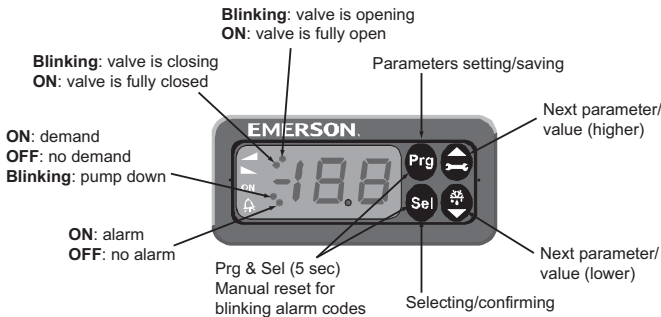

Control (valve) start-up behavior (Parameter uu and u9)

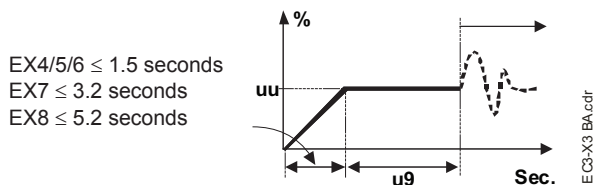

List of parameters in scrolling sequence by pressing **▲ button**

Code	Parameter description & choices	Min	Max	Factory Setting	Field Setting																									
H5	Password	1	199	12																										
u0	System Refrigerant 0 = R22; 1 = R134a; 2 = R507; 3 = R404A; 4 = R407C; 5 = R410A; 6 = R124; 7 = R744 (subcritical application)	0	7	1																										
uP	Installed pressure sensor type 0 = PT4-07M (for R22/R134a/R507/R404A/R407C/R124) 1 = PT4-18M (for R410A) 2 = PT4-30M (for R744, subcritical)	0	2	0																										
ut	Installed valve type 1 = EX4; 2 = EX5; 3 = EX6; 4 = EX7; 5 = EX8	1	5	5																										
uu	Start valve opening (%)	10	100	50																										
u9	Start opening duration (second)	1	30	5																										
uL	Low superheat alarm function 0 = disable (for flooded evaporator) 1 = enable auto reset 2 = enable manual reset Cut-out at 1°F (if it maintains 1 min.); Cut-in immediately at 3°F	0	2	1																										
u5	Superheat set-point (°F) If uL enabled (auto or manual) If uL disabled	5.4 0.9	54 54	10.8 10.8																										
u2	MOP function 0 = disable 1 = enable	0	1	1																										
u3	MOP set-point (°F) saturation temperature Factory setting is according to selected refrigerant (u0): +55°F for R22 +59°F for R134a +45°F for R507 +45°F for R404A +59°F for R407C +59°F for R410A +122°F for R124 +23°F for R744	*	*	X																										
┐ 1	Value to show 0 = Measured superheat (F) 1 = Measured evaporator pressure (psi) 2 = Valve opening (%) 3 = Measured coil-out temp. (°F) 4 = calculated evaporating temperature (°F) from the pressure	0	4	0																										
┐ 5	Units conversion 0 = °C, K, bar 1 = °F, R, psig (Psig values are divided by 10. Example: Display 12.5 is 125 psig)	0	1	0																										
u4	Superheat control mode 0 = Standard, 1 = Slow	0	1	0																										
uH	High superheat alarm function 0 = disable, 1 = enable auto reset	0	1	0																										
uA	High superheat alarm setpoint	16	40	30																										
ud	High superheat alarm delay, min.	1	15	3																										
P2	Freeze protection cut-out, °F	-40	104	32																										
P3	Freeze protection cut-in, °F	-35	109	37																										
P4	Freeze protection alarm function (0 = disable, 1 = enable auto-reset, 2 = enable manual reset)	0	2	0																										
P5	Freeze protection alarm delay, sec.	5	199	30																										
P6	Pump-down function (0 = disable, 1 = enable auto-reset)	0	1	0																										
P7	Pump-down cut-out, psig	-7.3	261.1	0.5																										
P8	Pump-down time delay, sec.	0	199	30																										
P9	Low pressure alarm function (0 = disable, 1 = enable auto-reset, 2 = enable manual reset)	0	2	0																										
PA	Low pressure alarm cut-out, psig	-11.6	256.7	0																										
Pb	Low pressure alarm delay, sec.	5	199	5																										
Pd	Low pressure alarm cut-in, psig	-7.3	261.1	0.3																										
b1	Battery error management, when battery is defective (EC3-X33 only), see below:	0	3	2																										
	<table border="1"> <thead> <tr> <th>Value</th> <th>Alarm Display</th> <th>Alarm Relay</th> <th>Valve</th> <th>Reset possibility after recovery/replacement</th> </tr> </thead> <tbody> <tr> <td>0</td> <td>-</td> <td>-</td> <td>Regulating</td> <td>-</td> </tr> <tr> <td>1</td> <td>Ab</td> <td>-</td> <td>Regulating</td> <td>-</td> </tr> <tr> <td>2</td> <td>Ab</td> <td>Signalling</td> <td>Fully close</td> <td>Auto</td> </tr> <tr> <td>3</td> <td>Ab (blinking)</td> <td>Signalling</td> <td>Fully close</td> <td>Manual</td> </tr> </tbody> </table>	Value	Alarm Display	Alarm Relay	Valve	Reset possibility after recovery/replacement	0	-	-	Regulating	-	1	Ab	-	Regulating	-	2	Ab	Signalling	Fully close	Auto	3	Ab (blinking)	Signalling	Fully close	Manual				
Value	Alarm Display	Alarm Relay	Valve	Reset possibility after recovery/replacement																										
0	-	-	Regulating	-																										
1	Ab	-	Regulating	-																										
2	Ab	Signalling	Fully close	Auto																										
3	Ab (blinking)	Signalling	Fully close	Manual																										
L2	Output logic 0: Alarm = normal, pump down. = normal 1: Alarm = inverse, pump down. = normal 2: Alarm = normal, pump down. = inverse 3: Alarm = inverse, pump down. = inverse	0	3	1																										

* Min. and Max. setting values are dependant to selected type of refrigerant.

Pump down function (if P6 = 1 and L2 = 1)

Digital input status	Alarm Condition	Pump down relay
24V (ON)	NO	Activate
0V (OFF)	NO	Deactivate when pressure drops below P7 and after elapsed time P8
0V or 24V	YES	Deactivate

Start-up

Start the system and check the superheat and operating conditions. The EC3-X32 is fully functional without connected PC or keypad/display unit ECD-002.

Dimensions

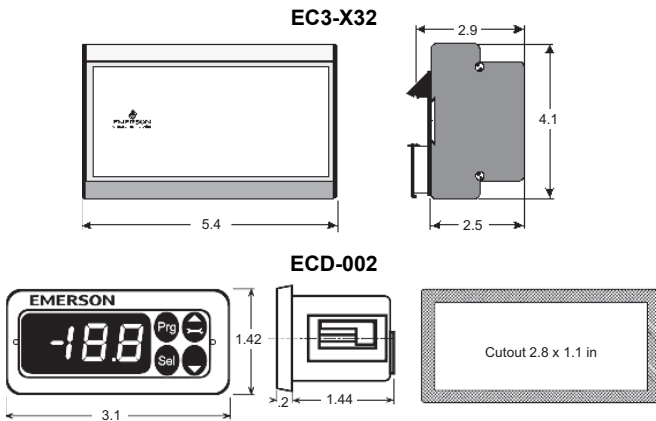

Mounting of ECD-002

ECD-002 can be installed at any time also during operation.

- ECD-002 can be mounted in panels with 2.8x1.1 in cutout
- Push controller into panel cut-out.(1)
- Make sure that mounting lugs are flush with outside of controller housing
- Insert allen key into front panel holes and turn clockwise. Mounting lugs will turn and gradually move towards panel (2)
- Turn allen key until mounting lug barely touches panel. Then move other mounting lug to the same position (3)
- Tighten both sides very carefully until keypad is secured. Do not over tighten as mounting lugs will break easily.

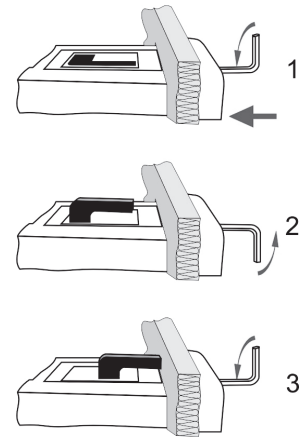

Error/Alarm Handling

Alarm code	Description	Related parameter	Alarm relay	Valve	What to do?	Requires manual reset after resolving alarm
E0	Pressure transmitter error	-	Signalling	Fully close	Check wiring connection and measure the signal 4 to 20 mA	No
E1	Temperature sensor error	-	Signalling	Fully close	Check wiring connection and measure the resistance of sensor	No
A[∇]	EX4...EX8 electrical connection error	-	Signalling	-	Check wiring connection and measure the resistance of winding	No
Ab Ab Ab blinking	Battery error	b1: 1 b1: 2 b1: 3	- Signalling Signalling	Regulating Fully close Fully close	Battery potentially does not have enough charge to close valve in case of main power supply interruption. May occur temporarily with new controllers or after long storage but should disappear when battery is charged sufficiently. If Ab remains active even when battery is charged, battery may be defective and should be replaced.	- - Yes
AE blinking	Pump down action can not be accomplished	P6: 1	Signalling	-	Allocate the source, which does not let suction pressure drops below desired set-point	Yes
AF AF blinking	Freeze protection	P4: 1 P4: 2	Signalling Signalling	Fully close Fully close	Check the system for cause of low pressure such as insufficient load on evaporator	No Yes
AL AL blinking	Low superheat (<1°F)	uL: 1 uL: 2	Signalling Signalling	Fully close Fully close	Check wiring connection and operation of valve	No Yes
AH	High superheat	uH: 1	Signalling	Fully close	Check the system	No
AP AP blinking	Low pressure	P9: 1 P9: 2	Signalling Signalling	Fully close Fully close	Check the system for cause of low pressure such as refrigerant loss	No Yes
Er	Data error display – out of range	-	-	-	Data send to the display is out of range. Check temperature and pressure sensor.	No

Note: When multiple alarms occur, the highest priority alarm is displayed until being cleared, then the next highest alarm is displayed until all alarms are cleared. Only then will parameters be shown again.

Message

— No data to display

The display will show an “—” at start up and when no data is sent to ECD-002

Checking system operating conditions using local display/keypad ECD-002

The data to be permanently shown on the display can be selected by the user (parameter $\square 1$). It is possible to temporarily display these values. However, this function is not available in an alarm condition. The display will show for one second the numerical

identifier of the data (see $\square 1$ parameter) and then the selected data. After 5 minutes, the display will return to the value selected by parameter $\square 1$.

Service/Troubleshooting

Symptom	Cause	Action
Operating superheat is several degrees higher or lower than set-point	Incorrect signal from pressure or temperature sensors	1- Check the sensors 2- Make sure ECN-N60 temperature sensor is used 3- For optimum accuracy, please use: PT4-07M for R22/R134a/R507/R404A/R407C/R124 PT4-18M for R410A PT4-30M for R744 4- Make sure the sensor cables are not installed along with other high voltage cables
Operating superheat is too low i.e. compressor wet running	1- Incorrect wiring of ECVs 2- Defective sensors	1- Check the wiring 2- Check the sensor
Valve is not fully closed	1- The digital input is ON (24V) 2- Wrong setting of parameter ut.	1- Valve is shut off only when the digital input is turned off (0V) 2- Check the setting of parameter ut
Instable superheat (hunting)	Evaporator is designed to operate at higher superheat	Increase the superheat set-point
Valve opens when EC3 commands to close and vice versa	Wrong wiring between EC3-X32 and valve	Correct the wiring
EX8 is not able to open at high differential pressure	Wrong setting of parameter ut	Check the parameter ut. (Larger valve requires higher torque and higher current)
Superheat set-point is shifting after several months of uninterrupted operation or permanent jumper of 24V digital input	Stepper motor driven valves require synchronization	Do not apply permanent 24V digital input. Interrupt digital input once every week for 5 seconds if compressor never stops.