

EX4-EX8 Electrical Control Valve

R-410A

EX Valves & Controls

The EX4-EX8 are stepper motor driven valves that are optimized for the control of liquid or gaseous mass flow in refrigeration systems. Multifunction capability as expansion valve, hot gas bypass, suction gas throttling, head pressure, liquid line actuator and other applications systems.

Features

- Fully hermetic design
- Fast full stroke time
- Applicable to all common refrigerants (HCFC, HFC), for subcritical CO₂ applications
- High resolution and excellent repeatability
- Bi-flow versions for heat pump applications
- Positive shut-off function to eliminate the use of an additional solenoid valve
- Linear flow capacity
- Wide capacity range (10 - 100%)
- Continuous modulation of mass flow, no stress (liquid hammering) in the refrigeration circuit
- Direct coupling of motor and valve for high reliability (no gear mechanism)
- Ceramic slide and port for accurate flow and minimal wear
- Balanced force design
- Corrosion resistant stainless steel body, and connections



Specifications

- CE marking: EX4/EX5: not required
EX6-EX8: required, Cat I, Module A
- MOPD: EX4-EX6: 580 psid, EX7-EX8: 435 psid
- MWP: 650 psig
- Ambient temperature: -40°F to +130°F
- Humidity: 5 to 95% R.H.
- External leakage: ≤ 0.1 oz/yr (R-22)
- Stepper motor type: Bi-polar, phase current by chopper control (constant current)
- Electrical connection: 4 pin terminal via plug
- Driver supply voltage: Recommended: 24 VDC
Range: 18-36 VDC
- Phase current (operating): EX4-EX6: 500 mA max
EX7: 750 mA
EX8: 800 mA
- Holding current: EX4-EX6: 100 mA
EX7: 250 mA
EX8: 500 mA
- Nominal input power per phase: EX4-EX6: 3.5W
EX7-EX8: 5W
- Phase inductance: EX4-EX6: 30 mH ±25%
EX7: 20 mH ±25%
EX8: 22 mH ±25%
- Step mode: 2 phase full step
- Step angle: 1.8° per step ±8%
- Total number of steps: EX4-EX6: 750 full steps
EX7: 1600 full steps
EX8: 2600 full steps
- Stepping rate: 500 Hz
- Winding resistance per phase: EX4-EX6: 13 ohm ±10%
EX7: 8 ohm ±10%
EX8: 6 ohm ±10%
- Full travel time: EX4-EX6: 1.5 seconds
EX7: 3.2 seconds
EX8: 5.2 seconds

Valve Type	Inlet x Outlet (ODF)	B	C	D	E	H1	H2
EX4-I21	3/8" x 5/8"	0.3	1.8	2.2	0.4	4.4	1.0
EX5-U21	5/8" x 7/8"	0.4	2.2	2.6	0.6	4.4	1.0
EX6-I21	7/8" x 1-1/8"	0.6	2.6	3.0	0.7	4.4	1.0
EX7-I21	1-1/8" x 1-3/8"	0.8	3.1	3.2	0.9	6.2	1.7
EX8-I21	1-5/8" x 1-5/8"	0.8	3.1	3.1	0.8	7.9	2.2

Dimensional Data (in)

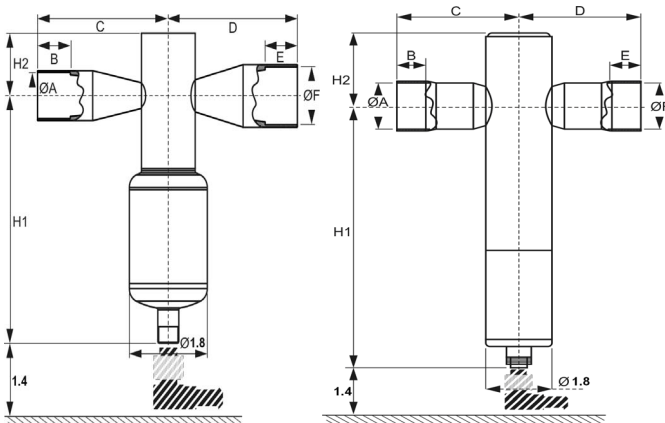

EX4/EX5/EX6/EX7/EX8

Nominal capacities as expansion valves and liquid injection valves

Nominal Capacities in Tons (10% - 100%)

Valve Type	R-407C	R-22	R-134a	R-404A	R-410A	R-23	R-124	R-744
EX4	.6 – 5	.6 – 4.7	.3 – 3.6	.3 – 3.3	.6 – 5.5	.6 – 5.1	.3 – 2.6	.9 – 9.5
EX5	1.4 – 15.1	1.4 – 14.2	1.1 – 11.1	1.1 – 10	1.7 – 16.5	1.4 – 15.4	.9 – 8	2.8 – 29
EX6	4.3 – 35.8	4.3 – 34.1	2.8 – 26.4	2.8 – 23.9	4.3 – 39.8	3.7 – 37	2 – 19.1	6.8 – 69.4
EX7	10 – 98.7	10 – 93.8	7.1 – 72.5	7.1 – 65.4	11.4 – 109.5	–	–	19.9 – 190.5
EX8	28.4 – 263	25.6 – 250.2	19.9 – 193.4	17.1 – 174.3	28.4 – 292	–	–	51.2 – 508.7

Note 1: EX Bi-flow versions are not released for use with R-124 and R-23 refrigerants.

Note 2: EX Bi-flow versions have identical capacity in both flow direction.

Refrigerant	Evaporating Temperature	Condensing Temperature	Subcooling
R-22, R-134a, R-404A, R-410A	+40 °F	+100°F	2°F
R-407C	+40°F dew point	+100°F bubble	2°F
R-124	+68°F	+176°F	2°F
R-23	-76°F	-13°F	2°F
R-744	-40°F	14°F	2°F

The nominal capacity is based on the following conditions:

Ordering Information

Description	Type	Inlet Connection (in)	Outlet Connection (in)	Reference #	PCN
EX4 Electrical Control Valve	EX4-I21	3/8	5/8	800615	097719
EX5 Electrical Control Valve	EX5-U21	5/8	7/8	800618	097720
EX6 Electrical Control Valve	EX6-I21	7/8	1 1/8	800620	097721
EX7 Electrical Control Valve	EX7-I21	1 1/8	1 3/8	800624	097722
EX8 Electrical Control Valve	EX8-I21	1 5/8	1 5/8	804631	097723
EX4 Bi-Flow Electrical Control Valve	EX4-U31	5/8	5/8	800617	097756
EX5 Bi-Flow Electrical Control Valve	EX5-U31	7/8	7/8	800619	097729
EX6 Bi-Flow Electrical Control Valve	EX6-I31	1 1/8	1 1/8	800622	097757
EX7 Bi-Flow Electrical Control Valve	EX7-U31	1 3/8	1 3/8	800626	097758
Valve Connector Cable	EXV-M60	N/A	N/A	804665	097741